



PAXTON

SUPERCHARGERS



Owners Installation Manual for the
PAXTON AUTOMOTIVE
NOVI 2000 Supercharger
for
1998-2001 Ford
6.8L V10

PAXTON AUTOMOTIVE 1300 BEACON PL. OXNARD CA 93033
(805) 604-1336 • FAX (805) 604-1337

FOREWORD

This manual provides information on the installation, maintenance and service of the Paxton supercharger kit expressly designed for the 1998-2001 Ford 6.8L V-10 F-250, F-350/Excursion. Contact Paxton Automotive Corporation for any additional information regarding this kit and any of these modifications at (805) 604-1336 8:00 a.m. - 4:30 p.m. P.S.T.

An understanding of the information contained herein will help novices, as well as experienced technicians, to correctly install and receive the greatest possible benefit from their Paxton supercharger. When reference is made in this manual to a brand name, number, specific tool or technique, an equivalent product may be used in place of the item mentioned. All information, illustrations and specifications contained herein are based on the latest product information available at the time of this publication. All rights reserved to make changes at any time without notice.

© **2005 PAXTON AUTOMOTIVE**

All rights reserved. No part of this publication may be reproduced, transmitted, transcribed, or translated into another language in any form, by any means without written permission of Paxton Automotive.

TABLE OF CONTENTS

FOREWORD	<i>.ii</i>
TABLE OF CONTENTS	<i>.iii</i>
IMPORTANT NOTES	<i>.iv</i>
INTRODUCTION	<i>.v</i>
TOOL & SUPPLY REQUIREMENTS	<i>.vii</i>
1. INITIAL PREPARATION AND DISASSEMBLY	1-1
1.1 AIR INTAKE DISASSEMBLY	1-1
1.2 FAN AND FAN SHROUD REMOVAL	1-2
1.3 POWER STEERING LINES MODIFICATION	1-2
1.4 WIRE ROUTING AND MODIFICATIONS	1-3
2. SUPERCHARGER ASSEMBLY INSTALLATION	2-1
2.1 OIL DRAIN LINE INSTALLATION	2-1
2.2 OIL FEED ASSEMBLY INSTALLATION	2-2
2.3 CRANK PULLEY ASSEMBLY INSTALLATION	2-2
2.4 S/C MOUNTING PLATE ASSEMBLY INSTALLATION	2-3
2.5 BELT TENSIONER/BELT INSTALLATION	2-3
3. DISCHARGE DUCT ASSEMBLY INSTALLATION	3-1
3.1 DISCHARGE DUCT ASSEMBLY INSTALLATION	3-1
4. SUPERCHARGER AIR INLET ASSEMBLY INSTALLATION	4-1
4.1 SUPERCHARGER INLET DUCT	4-1
4.2 AIR FILTER ENCLOSURE INSTALLATION	4-1
5. REINSTALLING FAN & SHROUD	5-1
5.1 REINSTALLING FAN & SHROUD	5-1
6. FUEL PUMP INSTALLATION	6-1
6.1 FUEL PUMP INSTALLATION	6-1
6.2 FUEL PUMP RELAY	6-1
6.3 FUEL CONTROL UNIT INSTALLATION	6-1
6.4 FUEL CONTROL UNIT VACUUM LINE	6-1
7. CHECK-OUT PROCEDURES	7-1
7.1 CHECK-OUT PROCEDURES	7-1
APPENDIX	A-1
A. APPENDIX TABLE OF CONTENTS	A-1
B. 1016111 ASY, NOVI 2000 SUPERCHARGER	A-2
C. 1016311 ASY, MOUNTING BRACKET	A-3
D. 1015611 ASY, CRANK PULLEY	A-4
E. 1016911 ASY, BELT TENSIONER	A-5
F. 1015911 ASY, AIR INTAKE	A-6
G. 1016011 ASY, AIR DISCHARGE	A-7
H. 1017711 ASY, FUEL CONTROL UNIT	A-8
I. 1017721 ASY, AUXILIARY FUEL SYSTEM	A-9
J. 1019344 ASY, SUPERCHARGER OIL RETURN	A-10
K. 1019350 ASY, SUPERCHARGER OIL FEED	A-11

Ford 6.8L Super Duty

IMPORTANT NOTES

1998-2001 Models

This kit requires ECM modification and the installation of a Paxton ECM Module. The ECM must be sent directly to Paxton by the installing customer (the charge for this service with module installation has been included in the purchase price).

- Included in this kit is a prepaid next-day air shipping box and a credit tag for one (1) Paxton ECM Module.
- The modules are made specifically for each individual vehicle with respect to the factory ECM calibration.
- Simply contact the Paxton Service Department at (805) 247-0226 to request a Return Authorization Number (see ECM Module Credit Tag for more details).
 - Mail to Paxton the enclosed "ECM Module Credit Tag" (send original tag - no photocopies will be accepted) and ECM in the supplied box.
 - Turnaround time will be 1-2 days (each application varies). Paxton will give an estimate at the time of your order.

Your Paxton ECM Module comes with a twelve (12) month limited warranty from the original date of purchase of your supercharger system (see Owner's Manual for details).

INTRODUCTION

Congratulations! You have purchased the finest street supercharger available for the Ford V10. The centerpiece of this kit is the High Efficiency NOVI 2000 Supercharger, a mechanically driven centrifugal supercharger.

This kit comes with all of the parts you will need to install the supercharger. This instruction manual has been grouped in order of sequence, with photographs and drawings to illustrate the text. This will allow you quick part identification and orientation.

We suggest that you obtain a Ford shop manual and become familiar with the details of your car's system. Manuals may be obtained from your local Ford dealer, or you can order one from Helm Publications at (800) 782-4356. If your vehicle is not within the normal operating parameters, we do not recommend the use of a supercharger.

For best results, we suggest that you read this entire manual before beginning. Familiarize yourself with the process and identify the areas of the car that you will be working on. The average installation time is 8 - 10 hours. Your actual install time will depend on your personal skill level, experience installing superchargers, working conditions, and preparedness for the job at hand. This estimate does not include time for the initial vehicle inspection, cleaning, fine tuning, or troubleshooting. Once again, before picking up a wrench, read this entire manual. We are available for technical assistance at (805) 604-1336.

After reading this manual, verify that all major assembly groups are present in the main kit box. You should have ample space to lay out the components. As you remove a box or bag from the main kit, note the identification label and compare it with the parts list.

Paxton makes every effort to ensure that all parts are included in the box, but mistakes do occur. If you discover that you are missing any part, or that a part was damaged in transit, please call Paxton for service. DO NOT attempt installation if any part(s) are missing from this kit. Failure to contact Paxton prior to beginning installation will result in a charge for any missing parts.

You are undoubtedly eager to get started with your project, but take a little more time to insure that your safety is not in jeopardy. A moment's lack of attention can result in an accident, as can failure to observe some simple safety precautions. The possibility of an accident always exists, and the following points should not be considered a comprehensive list of all of the dangers. They are only intended to make you aware of the risks and to encourage you to take a safety conscious approach to all of the work that you will be doing on your vehicle.

Never rely solely on a jack when working under a vehicle. Always use an approved set of jackstands to support the vehicle and place them under the recommended lift points.

When jacking a vehicle, make sure it is on a level surface, preferably concrete or asphalt. The transmission should be in "PARK" or "FIRST", the parking brake engaged and the wheels blocked.

Never start the car without first verifying that the transmission is in neutral and the parking brake is set.

Never remove the radiator cap while the engine is hot.

Always wear eye protection when using power tools such as drills, saws, grinders, etc., or when working under a vehicle.

Never smoke, use an open flame, or have spark-producing items around gasoline or flammable solvents. Always have a fire extinguisher rated for chemical and electrical fires handy when working on motor vehicles.

Run engines only in well ventilated areas. Carbon monoxide, gasoline, and solvent vapors are colorless and sometimes odorless. These can asphyxiate or explode without warning.

Always disconnect at least the negative (-) or ground terminal of the battery when doing any electrical, fuel system, or underdash work.

1998-2001 **FORD SUPER DUTY** Installation Instructions

1998-2001 50 State Smog Legal, as per CARB EO #P-195-19

Congratulations on selecting the best performing and best backed automotive supercharger available today... the NOVI 2000 Supercharger!

Before beginning this installation, please read through this entire instruction booklet and the Street Supercharger System Owner's Manual which includes the Automotive Limited Warranties Program and the Warranty Registration form.

Paxton supercharger systems are performance improving devices. In most cases, increases in torque of 30-35% and horsepower of 35-45% can be expected with the boost levels specified by Paxton Automotive. This product is intended for use on healthy, well maintained engines. Installation on a worn-out or damaged engine is not recommended and may result in failure of the engine as well as the supercharger. Paxton Automotive is not responsible for engine damage.

Installation on new vehicles will not harm or adversely affect the break-in period so long as factory break-in procedures are followed.

For best performance and continued durability, please take note of the following key points:

1. Use only premium grade fuel 91 octane or higher (R+M/2).
2. The engine must have stock compression ratio.
3. If the engine has been modified in any way, check with Paxton Automotive prior to using this product.
4. Always listen for any sign of detonation (pinging) and discontinue hard use (no boost) until problem is resolved.
5. Perform an oil and filter change upon completion of this installation and prior to test driving your vehicle. Thereafter, always use a high grade SF rated engine oil or a high quality synthetic, and change the oil and filter at least every 3,000 miles. Never attempt to extend the oil change interval beyond 3,000 miles, regardless of oil manufacturer's claims as potential damage to the supercharger may result.
6. Before beginning installation, replace all spark plugs that are older than 2 years or 30,000 miles with original heat range plugs as specified by the manufacturer and reset timing to factory specifications (follow the procedures indicated within the factory repair manual and/or as indicated on the factory underhood emissions tag). *Do not use platinum spark plugs unless they are original equipment.* Change spark plugs at least every 30,000 miles.

TOOL & SUPPLY REQUIREMENTS:

- Metric and standard - socket set, wrench set
- Ratchet - 1/2" drive
- Extension
- 1/2" drive breaker bar
- Ford springlock tool 3/8" & 1/2"
- Pliers
- Drill motor
- Ø1/16" and #30, Ø9/32", and Ø11/16" drill bits
- Test light
- Rubber mallet or dead blow hammer
- Wire cutters and crimping tool
- Standard hex key set (Allen wrenches)
- Silicone sealer/RTV

If your vehicle has in excess of 30,000 miles since its last spark plug change, then you will also need:

- Spark Plug Socket
- NEW Spark Plugs

We look forward to hearing from you, particularly if you have any comments or suggestions regarding this manual.

TRANSMISSION WARNING/DISCLAIMER:

Due to the increased horsepower and torque generated by the Paxton Novi 2000 supercharger, your transmission may require modification to prevent premature wear or damage—especially if plan to use your vehicle in high demand situations, such as towing. In any case, it is a good idea to consider purchasing a transmission valve body kit (commonly known as a shift improver kit) to improve transmission performance and durability. Several companies offer valve body kits, including TransGo Performance. Please contact TransGo or the valve body kit manufacturer of your choice for more information, pricing, labor involved, etc.

TransGo Performance
2621 Merced Ave.
El Monte, CA. 91733
(818) 443-4953
FAX: (818) 443-1079

NOTE:

This information is provided for customer convenience only. Paxton Automotive does not endorse any valve body kit manufacturers and does not provide warranty or service on said products.

PLEASE NOTE:

The 2000 Ford 6.8L V10 has several minor changes in the design of the engine. Those changes have been included in this manual. Please be aware of the model year of the vehicle, and follow the proper set of directions.

Section 1

INITIAL PREPARATION AND DISASSEMBLY

1.1 AIR INTAKE DISASSEMBLY

- A. Using a screwdriver, remove the black rubber tube between the throttle body and the air cleaner by loosening the two hose clamps. Disconnect the two rubber hoses attached to the side of the tube. (See Fig. 1.1-a.)



Fig. 1.1-a

- B. Carefully pull the air inlet temperature sensor out of the black rubber hose attached to the side of the plastic inlet tube. (See Fig. 1.1-b.)

*** NOTE ***

Model Year 2000 will NOT have this sensor.



Fig. 1.1-b

- C. Un-snap the large clamp which holds the air cleaner housing together and remove the sec-

tion between the throttle body and front air filter enclosure. You will need to unplug the Mass Airflow Sensor connector on the inner fenderwell. Using a 10mm socket and ratchet, remove the three bolts securing the air filter bracket and remove it from the vehicle. (See Fig. 1.1-c.)



Fig. 1.1-c

- D. Gently pry the air flow meter cover plate from the air filter housing using a screwdriver. Next, push the large rubber grommet (surrounding the 4 Mass Airflow Meter wires) into the housing and finish removing the Mass Airflow Meter. (See Fig. 1.1-d.)



Fig. 1.1-d

- E. Remove the two 10mm nuts retaining the MASS AIR FLOW METER and separate the two pieces. (See Fig. 1.1-e.)



Fig. 1.1-e

The MASS AIR FLOW METER will be used in a later step. Discard the MASS AIR FLOW METER housing, face plate and air cleaner assembly.

- F. Remove the large nut from the support bracket on top of the fan shroud cover. Next, remove the three 8mm bolts securing the coolant reservoir and set the reservoir on the passenger side inner-fender. Next, drain the coolant from the engine by opening the petcock on the bottom of the radiator, driver's side. Mark the ends of the upper radiator hose with an "R" on the radiator side and a "T" on the thermostat housing end. This is required for a later step.

1.2 FAN AND FAN SHROUD REMOVAL

- A. Unscrew the fan from the water pump using a 48mm open end wrench or large crescent wrench and the supplied fan removal tool .
- B. Slide the fan removal tool over the four bolts securing the water pump pulley to the water pump.

***** NOTE *****

The nut has right-handed threads. Remove the two 8mm bolts retaining the fan shroud located at the top of the fan shroud on the driver's side and passenger's side.

Using a 1/2" breaker bar for leverage, hold the pulley so it does not move and loosen the fan assembly from the water pump snout.

- C. Remove the fasteners that secure the fan shroud to the radiator.
- D. After you remove the fan from the water pump, lift the fan and fan shroud together from the engine compartment and set it aside to be reinstalled at a later step. (See Fig. 1.2-a.)



Fig. 1.2-a

1.3 POWER STEERING LINES MODIFICATION

- A. Unbolt the charcoal canister and the bracket, (the large black cylinder unit on the driver's side inner-fenderwall). Swing the bracket back and out of the way.
- B. Next, you will need to remove the power-steering reservoir, insuring the fill cap is on tight, turn the reservoir upside down and remove both lines. Being careful not to spill any fluid, shorten the larger hose 1-1/4" and the smaller hose, 4".
- C. Reroute both lines under the two steel brake lines running toward the front of the engine compartment. Re-attach the two hoses to the power steering reservoir and the P/S Relocation bracket provided, re-attach the reservoir and replenish any fluid spilled during the process.

1.4 WIRE ROUTING AND MODIFICATIONS

- A. On the front of the engine, (driver's side), you will find two large black electrical connectors attached to a bracket. (See Fig. 1.4-a.)



Fig. 1.4-a

- B. Remove plugs from the bracket (see Fig. 1.4-b) and disconnect both plugs; one requires a 10mm socket wrench.



Fig. 1.4-b

- C. Next, unbolt the bracket that held the two electrical connectors and modify the bracket as in (See Fig. 1.4-c.)

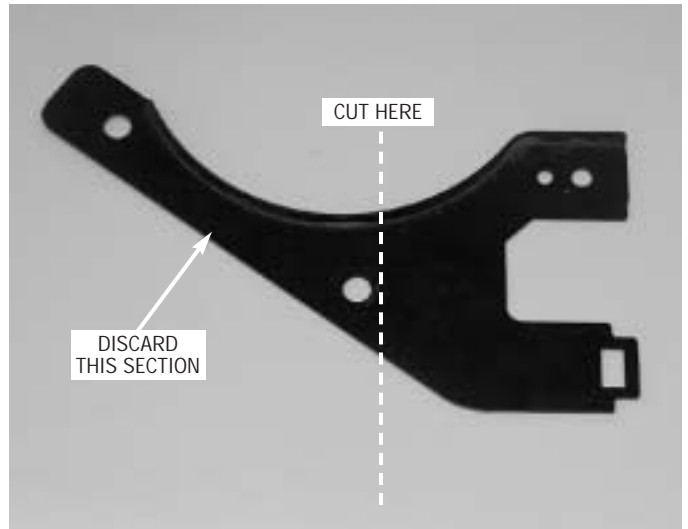

Fig. 1.4-c

- D. Discard the part with the two holes in it and retain the section that the electrical connectors clip to. The two connectors and wiring harness, will now be routed directly in front of the two steel brake lines.
- E. Lift the wiring harness in the plastic sheath off the studs on the driver's side valve cover. Push it down into the area between the valve cover and the intake manifold. Now take the large wiring harness and two connectors that runs along the top of the motor and fold the wiring harness back onto itself as shown. (See Fig. 1.4-d.)



Fig. 1.4-d

- F.** Reclip the two large connectors back onto the modified stock bracket (from Step E). Attach the bracket and connectors with the two supplied wire ties to the heavy-duty plastic wire loom as shown. (See *Fig. 1.4-e.*)



Fig. 1.4-e

- G.** Located on the driver's side, in front of the cylinder head is the cam sensor. Extend the two wires coming from the cam sensor along with the shielded white wire that runs parallel with the cam sensor wires, using the supplied three wires and six Butt connectors. (See *Fig. 1.4-f.*)



Fig. 1.4-f

- H.** Then cover the wires with the supplied split-loom. Route the extended wires under the upper most stud sticking out of the front of the engine then back over toward the harness.

Section 2

SUPERCHARGER ASSEMBLY INSTALLATION

2.1 OIL DRAIN LINE INSTALLATION

- A. Locate the supplied oil drain assembly #1019344. Mark the front of the oil pan 1 inch below the pan rail and between the two pan rail bolts, directly in the center of the small “hump” (see Appendix J).
- B. Drill a pilot hole with a 3/16" drill bit. Smear the drill bit with heavy grease first to prevent small metal particles from falling into the pan.
- C. Insert a straight length of welding rod or heavy wire (such as a coat hanger) into the hole approximately three inches to make sure no interference is encountered. If the path is blocked, turn the engine over until the pathway is clear.
- D. Apply a small amount of anti-seize lubricant to the tip of the punch, and insert it into the pilot hole. Hit the punch with an air hammer carefully using small bursts, until the punch is inserted up to the line as shown. The finished hole size should be no larger than 9/16" in diameter. (See Fig 2.1-a.)

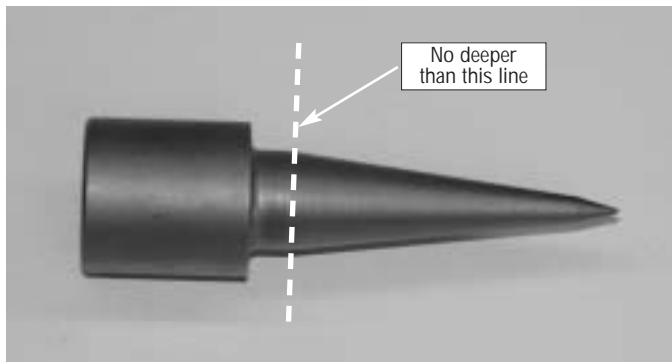

Fig 2.1-a

***** NOTE *****

Do not use hand tools. Using an ordinary hammer will dent the pan. Use extreme caution not to make the hole too big, or the drain fitting will not fit.

- E. Apply a liberal amount of heavy grease to a 3/8"-18 NPT tap (not included), and gradually thread into the hole. Clean the threads using a clean rag and an approved solvent, such as carburetor cleaner. (See Fig. 2.1b.)



Fig 2.1-b

- F. Apply an ample amount of silicone RTV to the threads of the supplied 3/8"NPT x 1/2" hose barb fitting installing the fitting in the previously tapped hole.

2.2 OIL FEED ASSEMBLY INSTALLATION

- A. Locate the supplied oil feed line in the Assy 1019350. On the passenger-side cylinder head, there is a small pipe plug, near the front and below the oil fill neck.
- B. Using a 3/16" allen wrench, remove the allen plug. Install the 1/8"NPT x -4 x 90° supplied fitting. The 1/8"NPT x -4 x 90° fitting, when installed, should be pointing straight up. (See Fig. 2.2-a.)



Fig 2.2-a

Attach the oil feed line and route it over to the driver-side underneath the alternator.

***** NOTE *****

Supercharger and oil feed line will be installed during a later stage of the installation.

- C. Install the 1/8"NPT x -4 x 90° oil feed line fitting into the brass oil jet fitting into the blower. Use only engine oil on the oil feed jet fitting. *Using a thread sealant may clog the oil jet orifice and damage the supercharger.*

***** NOTE *****

Support the oil jet with an open end wrench to prevent snapping off the fitting during installation of the 1/8"NPT x -4 x 90° fitting.)

2.3 CRANK PULLEY ASSEMBLY INSTALLATION

- A. Locate the supercharger crank pulley Assembly 1015611 that is provided.
- B. Bolt the Paxton Supercharger crank pulley to the face of the stock crank pulley, using the (3) supplied allen-head bolts. (See Fig. 2.3-a.)

***** NOTE *****

Apply Loc-Tite thread lock to threads.

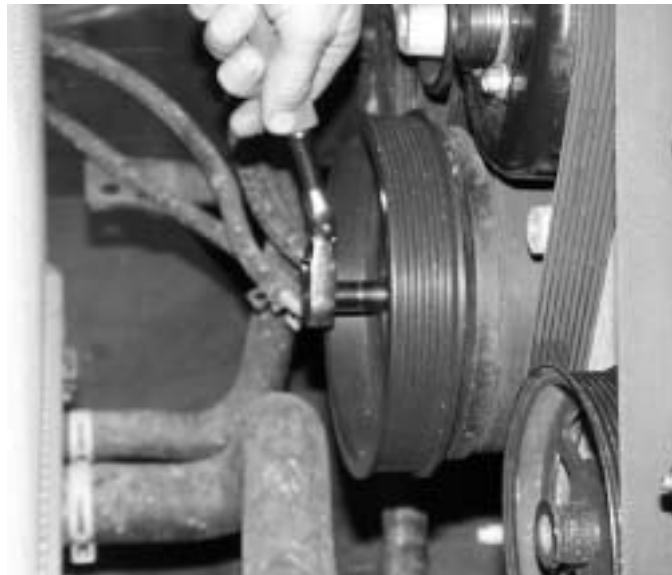

Fig 2.3-a

- C. After the supplied pulley is installed check and confirm that the pulley is sitting flush with the face of the factory pulley.

2.4 S/C MOUNTING PLATE ASSEMBLY INSTALLATION

- A. Slide the three black aluminum spacers, about 1/2" thick, over the three studs protruding from the front of the driver's side head.
- B. Slide the supercharger mounting bracket over the studs and spacers and attach with the supplied three nuts and one bolt.(Appendix "C".) Hand tighten only at this time.
- C. Slide the mounting block between the supercharger side-brace and the cylinder head. Secure with the supplied 14mm x 2 x 50mm long bolts, inserting through the side support bracket through the mounting block and directly into the cylinder head. Tighten all of the fasteners that were left finger tight in Step "B".
- D. Bolt the supercharger to the mounting bracket using the six 3/8-16 x 2.0" bolts and washers provided. (See Fig. 2.4-a.)
- E. Attach the oil feed line, installed during an earlier step, to the 1/4"NPT x -4 x 90°NPT fitting installed in the supercharger.



Fig 2.4-a

2.5 BELT TENSIONER/BELT INSTALLATION

- A. Install the spring loaded tensioner and tensioner mounting plate to the front cover of the supercharger using two countersunk allen head bolts and one 3/8-16 x 2.75"L bolt. (See Appendix "E".)
- B. Install the supercharger belt by looping the belt around the crank pulley, and then around the supercharger pulley. You will need to rotate the tensioner out of the way to do this. The belt must be positioned so it is against the face of the two idler pulleys. The belt will be twisted sideways when it goes over the front of the idlers. Next, with the tensioner rotated out of the way, slip the belt under the grooved idler then under the smooth idler.(See Appendix "D".)

This Page Left Intentionally Blank

Section 3

DISCHARGE DUCT ASSEMBLY INSTALLATION

3.1 DISCHARGE DUCT ASSEMBLY INSTALLATION

- A. Locate discharge Assembly 1016011.
- B. Install the supplied 3.0" x 2.0"L sleeve to the discharge duct by pushing the sleeve all the way onto the discharge tube.
- C. Attach the 4.25" x 2.0"L sleeve to the throttle body with the clamps provided.
- D. Position the discharge tube between the throttle body and the supercharger. Slide both sleeves into position and secure with the supplied hose clamps. (See *Fig 3.1-a*.)

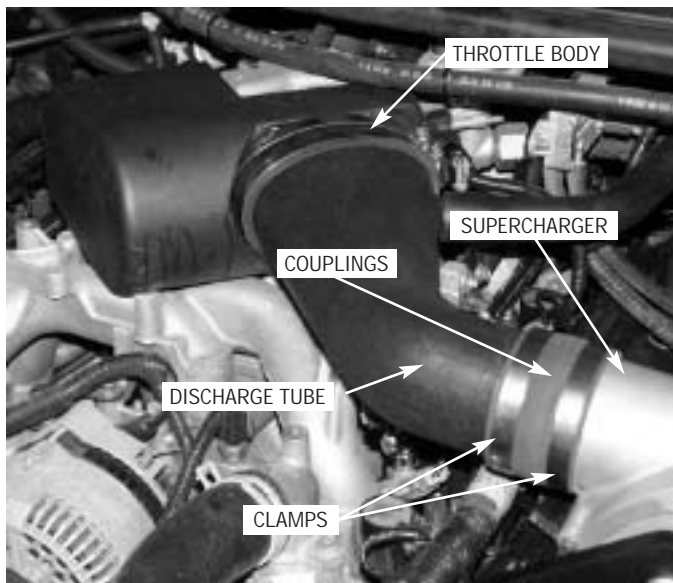

Fig 3.1-a

- E. Attach idle air bypass hose to the nipple on the discharge tube with the supplied clamp. (See Appendix G.)

This Page Left Intentionally Blank

Section 4

SUPERCHARGER AIR INLET TUBE

4.1 SUPERCHARGER INLET DUCT

- A. Locate the supplied inlet duct Assembly 1015911 in the kit. Plug the air temp sensor, previously removed in an earlier step, into the open hole on the rubber elbow. (See Fig. 4.1-a.)

***** NOTE *****

Model year 2000 - engines will not have this sensor. Install the supplied plug into the location where the IAT sensor would be. It is recommended that sealant be used on this plug.

- B. Slide the inlet hose with the attached aluminum elbow in behind the supercharger and attach to the inlet of the supercharger with the supplied hose clamp. (See Appendix "F".) The electrical harness will go through the loop in the inlet tube. (See Fig. 4.1-a.)

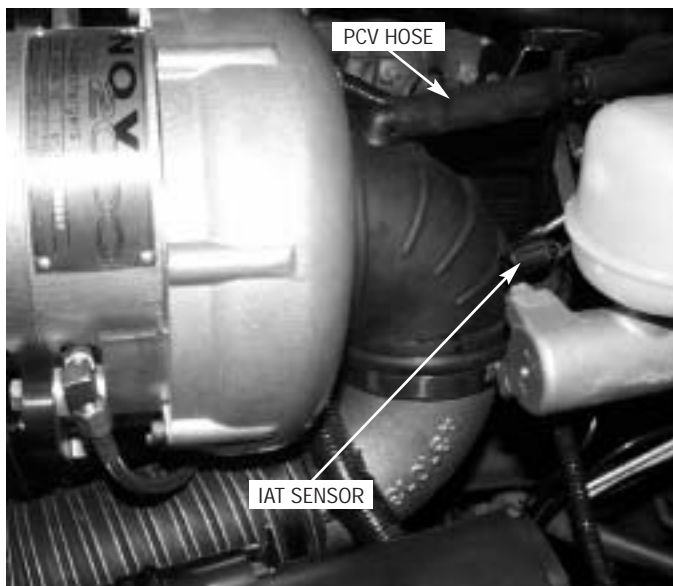

Fig 4.1-a

- C. Twist and rotate the elbow for the best possible fit.

***** NOTE *****

The rubber elbow will point straight down, the aluminum elbow will point outward slightly.)

- D. Rotate the rubber elbow toward the engine until there is clearance between the electrical connection on the master cylinder and the elbow. You will have to relocate the cruise control sensor with the supplied TEE assembly for clear-

ance. Attach the flex hose to the aluminum elbow. Next, connect the factory PCV hose into the hose coming from the intake elbow. (See Fig. 4.1-a.)

4.2 AIR FILTER ENCLOSURE INSTALLATION

- A. Locate the new air filter cover. Attach the new air cleaner to the aluminum four bolt flange adapter using the supplied hose clamp. Bolt the air flow meter to the adapter flange sandwiching the air filter cover in between. (See Appendix "F".) Next, use a razor blade or sharp knife to remove the rubber flap with the large hole in it (located on the core support next to the radiator on the driver's side). Fold the other rubber flap against the side of the radiator. This will help to seal the airbox. Remove the three bolts that correspond with the mounting holes in the filter cover and attach, re-using the same bolts. (See Fig. 4.2-a.)



Fig 4.2-a

- B. Slide the inlet hose onto the Air Flow Meter and secure with supplied hose clamps. Plug in the Air Flow Meter wiring harness.

***** NOTE *****

There is a large Venturi that goes in after the MAF sensor. This Venturi actually increases bottom and mid range torque while limiting the total boost to 8 PSI. Removal of this venturi will make your vehicle slower and subject the engine to damage due to overboost.

This Page Left Intentionally Blank

Section 5

REINSTALLING FAN AND SHROUD

5.1 REINSTALLING FAN & SHROUD

- A. Install the supplied fan spacer to the factory fan clutch. (See Fig. 5.1-a.)



Fig 5.1-a

- B. Slide the fan and fan shroud (see Fig. 5.1-b) simultaneously in place and screw the fan onto the water pump.



Fig 5.1-b

- C. Re-install the fan shroud, re-attach the coolant reservoir. Re-install the upper radiator hose to the radiator and the end marked "R" to the thermostat housing (**reversing the hose**). This is done to clear the supercharger bracket. Fill radiator reservoir per the manufacturer's specification. (See Fig. 5.1-b.)

This Page Left Intentionally Blank

Section 6

FUEL PUMP INSTALLATION

6.1 FUEL PUMP INSTALLATION

***** NOTE *****

Depressurize the fuel system by removing the cap on the schraeder valve and depressing the valve using a pen or small screwdriver to release fuel pressure. Cover the valve with a rag while this is being done to prevent fuel spray.

- A. Locate the fuel filter inside the driver's side frame rail. Using the appropriate size fuel disconnect tool, disconnect the fuel line on the output side of the fuel filter. Connect the fuel pump inlet line to the disconnected port on the fuel filter and the fuel pump outlet line to the disconnected line going to the engine. (See Fig 6.1-a.)



Fig 6.1-a

***** NOTE *****

Hoses are left intentionally long so you have the freedom in mounting.

- B. Trim lines as necessary. Route all fuel lines away from any heat source or moving parts and secure using supplied clamps and wire ties.

6.2 FUEL PUMP RELAY

- A. Mount the relay in a safe, dry place in the engine compartment away from any heat source. Wire the relay as per Appendix "I". On terminal 86, tap in the pink with black stripe wire that is located in the wiring harness labeled "FS" going to the fuel pump.

6.3 FUEL CONTROL UNIT INSTALLATION

- A. Locate the fuel return line quick connect in the frame rail on the driver's side. Disconnect the line and install the fuel control unit as per Appendix "H". Route all fuel lines away from any heat source or moving parts and secure using supplied wire-ties. Drill two 5/16" holes in frame and mount the FCU using supplied hardware. (See Fig 6.3-a.)



Fig 6.3-a

***** NOTE *****

Some vehicles already have holes on the bottom side of the frame rail that line up with the FCU mounting holes.

6.4 FUEL CONTROL UNIT VACUUM LINE

- A. Next, run the supplied vacuum line up to the engine compartment. On vehicles with vacuum boosted brakes, cut the vacuum line going to the brake booster and install the supplied vacuum TEE, connect the FCU vacuum line to the TEE. On vehicles with Hydro-Boost brakes, route the FCU vacuum line to the capped port on the passenger side of the Intake manifold next to the throttle body.

This Page Left Intentionally Blank

Section 7

CHECK-OUT PROCEDURES

7.1 CHECK-OUT PROCEDURES

- A. We know that you are anxious to get out and drive your new vehicle, but please take a little bit more time to perform these simple check-out steps.
- B. Now that the work is done, it's time to enjoy. PAXTON Automotive wants to thank you for choosing our product, and wants to remind you that the performance and response of your vehi-

cle is now different than what you are used to. Please drive cautiously until you have grown accustomed to the feel of your vehicle.

- C. Please see the service manual included in your kit for information on the service and maintenance of your PAXTON Supercharger. Belt tightening, troubleshooting, special tuning requirements, and warranty information is also included in the Service Manual.

- A. Inspect all wiring harnesses and electrical connections. Make sure that all items are properly routed, connected and secured.
- B. Check all hoses, lines, and fittings for properly secured connections.
- C. Make certain all fasteners, brackets, and clamps are installed and properly tightened.
- D. Check serpentine accessory belt and supercharger drive belts for proper tension and alignment.
- E. Cycle ignition key from "off" to the "on" position.
- F. Check the entire fuel system for possible leaks.
- G. Start engine and verify that the oil pressure is within normal range.
- H. Allow the engine to come up to normal operating temperature.
- I. Check the coolant level in the coolant recovery bottle and top off as needed.
- J. Check the following:
 - Fluid Leaks
 - Fluid Levels
 - Belt Slippage
 - Throttle Response

This Page Left Intentionally Blank

APPENDIX

Please understand that Paxton Automotive is constantly improving the NOVI supercharger system. As a result, some of the parts in your kit may not look exactly like the parts pictured in this manual. This may be due to pictures taken in pre-production, a change in materials, or even in a change in the design in the vehicle from one model year to the next.

Rest assured that your supercharger kit is the most up-to-date kit that Paxton produces for your vehicle at this time. All of the parts will install in the same manner as shown in this manual.

APPENDIX TABLE OF CONTENTS

APPENDIX	DRAWING NO.	REV	TITLE OF DRAWING
A	1001911	H	KIT, PARTS LIST
B	1016111	D	ASY, NOVI 2000 SUPERCHARGER
C	1016311	C	ASY, MOUNTING BRACKET
D	1015611	B	ASY, CRANK PULLEY
E	1016911	E	ASY, BELT TENSIONER
F	1015911	F	ASY, AIR INTAKE
G	1016011	C	ASY, AIR DISCHARGE
H	1017711	C	ASY, FUEL CONTROL UNIT
I	1017721	J	ASY, AUX. FUEL SYSTEM
J	1019344	NC	ASY, S/C OIL RETURN
K	1019350	NC	ASY, S/C OIL FEED
L	1018006	C	ASY, WIRE EXT, CAM SENSOR
M	1018011	NC	ASY, CRUISE CONTROL SENSOR RELOC.

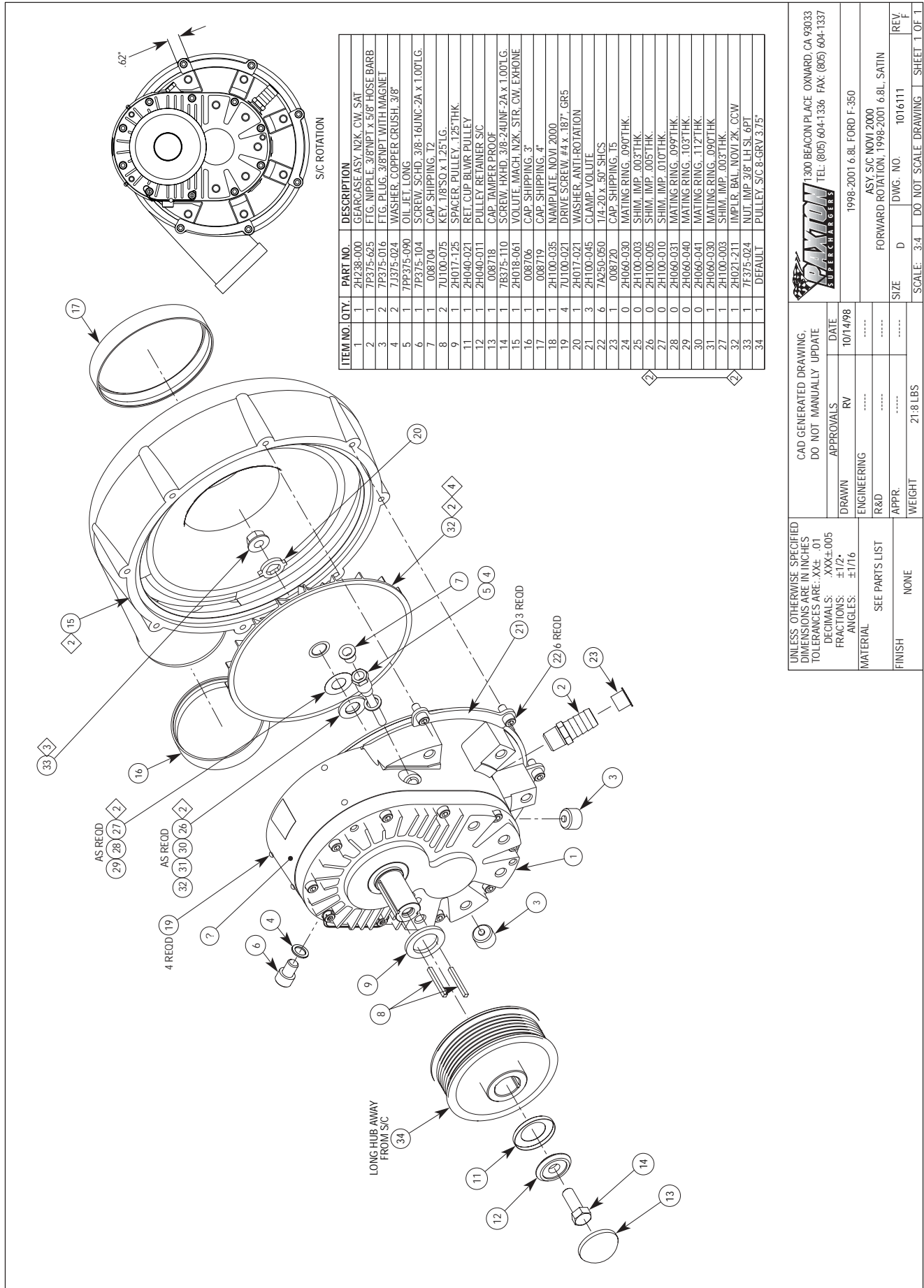

ITEM NO.	QTY.	PART NO.	DESCRIPTION
1	1	2H238-000	GEARCASE ASY. N2K. CW. SAT
2	1	7P375-625	FTG. NIPPLE. 3/8"NPT x 5/8" HOSE BARB
3	2	7P375-016	FTG. PLUG. 3/8"NPT WITH MAGNET
4	2	7J875-024	WASHER. COPPER CRUSH. 3/8"
5	1	7P375-090	OIL JET LONG
6	1	7P375-104	SCREW. SCHD. 3/8-16UNC-2A x 1.00"LG.
7	1	008704	CAP. SHIPPING. T2
8	2	7U100-075	KEY. 1/8"SQ x 1.25"LG.
9	1	2H017-125	SPACER. PULLEY. 1.25"THK.
11	1	2H040-021	RET. CUP BLWR PULLEY
12	1	2H040-011	PULLEY RETAINER S/C
13	1	008718	CAP. TAMPER PROOF
14	1	7B375-110	SCREW. HXHD. 3/8-24UNF-2A x 1.00"LG.
15	1	2H018-061	VOL. LITE. MACH N2K. STR. CW. EXHONE
16	1	008706	CAP. SHIPPING. 3"
17	1	008719	CAP. SHIPPING. 4"
18	1	2H100-035	NAMPLATE. NOV1. 2000
19	4	7U100-021	DRIVE SCREW. #4 x .187. GR5
20	1	2H017-021	WASHER. ANTI-ROTATION
21	3	2H100-045	CLAMP. VOLUTE
22	6	7A250-050	1/4-20 x .50" SHCS
23	1	008720	CAP. SHIPPING. T5
24	0	2H060-030	MATING RING. .090"THK.
25	0	2H100-003	SHIM. IMP. 003"THK.
26	0	2H100-005	SHIM. IMP. 005"THK.
27	0	2H100-010	SHIM. IMP. 010"THK.
28	0	2H060-031	MATING RING. .090"THK.
29	0	2H060-040	MATING RING. .103"THK.
30	0	2H060-041	MATING RING. .112"THK.
31	1	2H060-030	MATING RING. .090"THK.
32	1	2H021-211	IMPLR. BAL. NOV1. 2K. CCW
33	1	7F375-024	NUT. IMP. 3/8" LH SL. 6PT
34	1	DEFAULT	PULLEY. S/C 8-GRV 3.75"

UNLESS OTHERWISE SPECIFIED
 DIMENSIONS ARE IN INCHES
 TOLERANCES ARE: XXX+.01
 DECIMALS: XXX+.005
 FRACTIONS: ±1/2"
 ANGLES: ±1/16"

CAD GENERATED DRAWING.
 DO NOT MANUALLY UPDATE

DATE: 10/14/98

APPROVALS: RV

ENGINEERING: R&D

APP: APPR

WEIGHT: 21.8 LBS

FINISH: NONE

SEE PARTS LIST

MATERIAL: -----

SCALE: 3:4 DO NOT SCALE DRAWING

SIZE: D

DWG. NO.: 1016111

REV: 1

1998-2001 6.8L FORD F-350
 ASY, S/C NOV1 2000
 FORWARD ROTATION, 1998-2001 6.8L SATIN

PAXTON
 AUTOMOTIVE

1300 BEACON PLACE OXNARD, CA 93033
 TEL: (805) 604-1336 FAX: (805) 604-1337

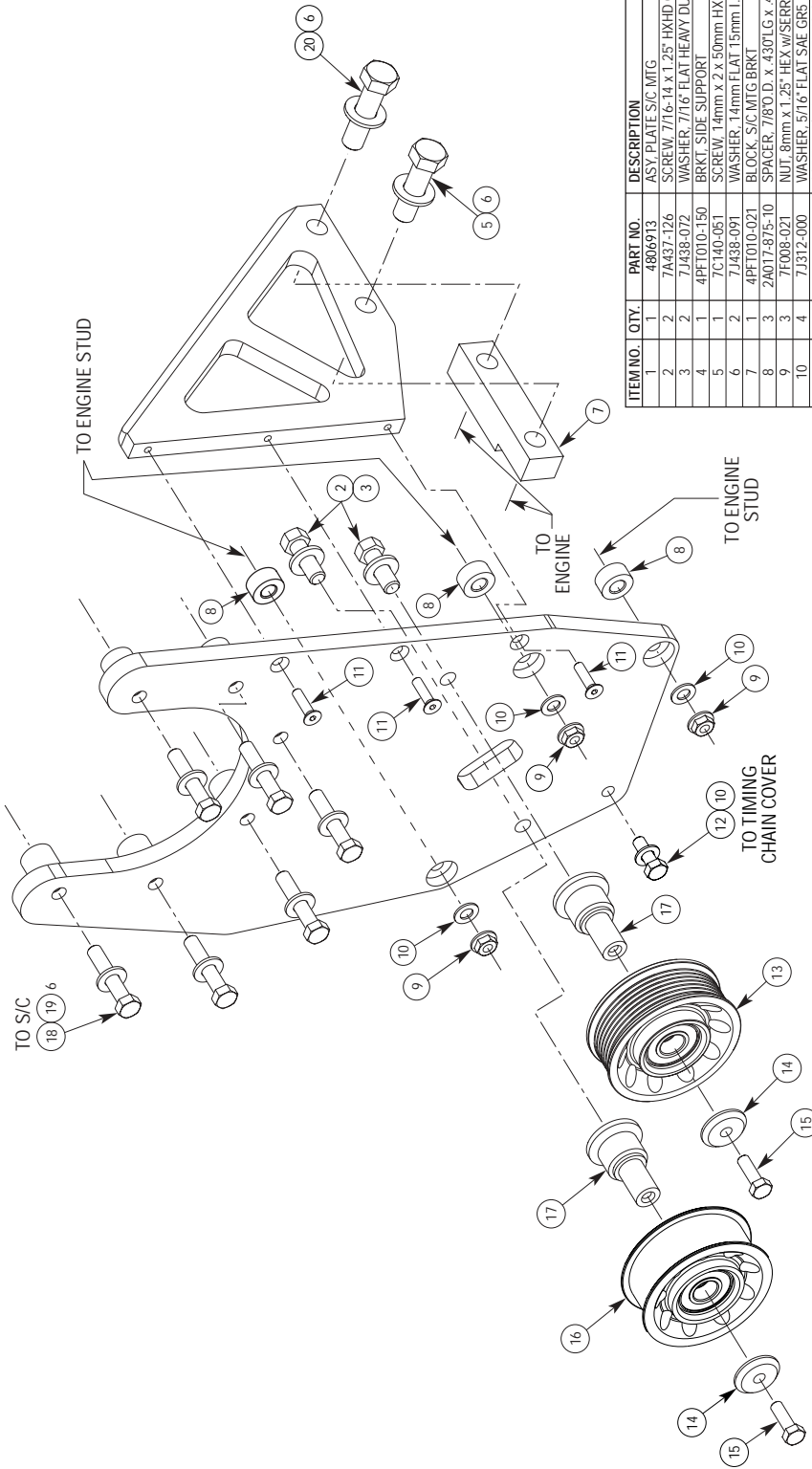

ITEM NO.	QTY.	PART NO.	DESCRIPTION
1	1	4806913	ASY PLATE S/C MTG
2	2	7A437-126	SCREW 7/16-14 x 1.25 HXHD GR8
3	2	7J438-072	WASHER 7/16 FLAT HEAVY DUTY 15/16 x 7/64 THK GR8
4	1	4PF1010-150	BRKT. SIDE SUPPORT
5	1	7C140-051	SCREW 14mm x 2 x 50mm HXHD CLASS 10.9
6	2	7J438-091	WASHER 14mm FLAT 15mm I.D. x 28mm O.D. x 2.5mm
7	1	4PF1010-021	BLOCK S/C MTG BRKT
8	3	2M017-975-10	SPACER 7/8" O.D. x 430" L.G. x 406" I.D.
9	3	7F008-021	NUT 8mm x 1.25 HEX w/SERRATED FLANGE CLASS B
10	4	7J312-000	WASHER 5/16 FLAT SAE GR5
11	3	7A250-100	SCREW 1/4-20 x 1.00 FLHS GR5
12	1	7C080-025	ASY PULLEY IDLER 8-GRV Ø3.535" P
13	1	1210501	RETAINER IDLER PULLEY
14	2	4PFM017-071	ASY IDLER PULLEY SMOOTH FACE Ø3.25"
15	2	7B312-100	SCREW 5/16-24 x 1.00 HXHD SST w/NYLOCK
16	1	1210502	COLLAR STEP w/HD 8-GRV
17	2	4PFM017-081	ASY IDLER PULLEY SMOOTH FACE Ø3.25"
18	6	7A375-200	SCREW 3/8-16 x 2.00 HXHD GR5
19	6	7J975-044	WASHER 3/8" O.D. x .75" O.D. x .09" THK
20	1	7C140-055	SCREW 14mm x 2 x 55mm HXHD CLASS 10.9

UNLESS OTHERWISE SPECIFIED
 DIMENSIONS ARE IN INCHES
 TOLERANCES ARE: .XXX ± .005
 DECIMALS: .XXX ± .005
 FRACTIONS: ± 1/2
 ANGLES: ± 1/16

CAD GENERATED DRAWING
 DO NOT MANUALLY UPDATE
 APPROVALS: JFC DATE 10/26/98
 DRAWN: JFC
 ENGINEERING: R&D
 SEE PARTS LIST
 FINISH: NONE WEIGHT: 12.6 LBS

1998-2001 FORD 6.8L V-10
 ASY, S/C MTG BRKT
 SCALE: 1:1.5 DO NOT SCALE DRAWING SHEET 1 OF 1



1-300 BEACON PLACE ONYARD, CA 93033
 TEL: (805) 604-1336 FAX: (805) 604-1337

Appendix C 1016311 ASY, MOUNTING BRACKET

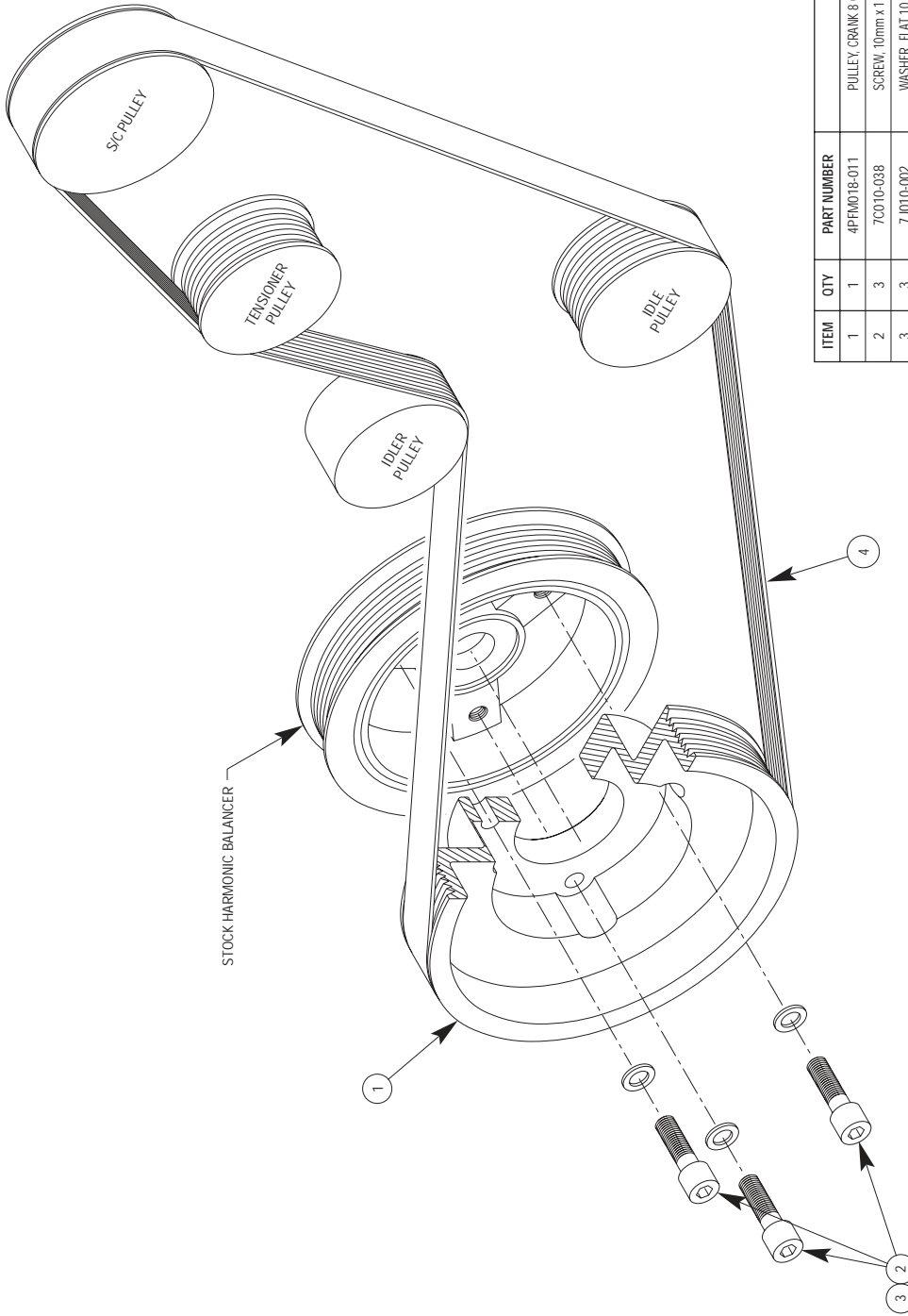

ITEM	QTY	PART NUMBER	DESCRIPTION
1	1	4PFM018-011	PULLEY, CRANK 8 GRV/97-98 5.4L F250 4WD
2	3	7C010-038	SCREW, 10mm x 1.5 x 35mm SHCS CLASS 12.9
3	3	7J010-002	WASHER, FLAT 10.5mm I.D. x 20mm O.D. x 2mm THK
4	1	2A048-740	BELT, 8 GRV POLY COG 74.0" x 1-1/8" WIDE

UNLESS OTHERWISE SPECIFIED DIMENSIONS ARE IN INCHES TOLERANCES ARE: .XXX ± .01 DECIMALS: .XXX ± .005 FRACTIONS: ±1/2 ANGLES: ±1/16		CAD GENERATED DRAWING. DO NOT MANUALLY UPDATE		DATE 10/30/98	
MATERIAL SEE PARTS LIST		DRAWN JFC		APPROVALS	
FINISH NONE		ENGINEERING		DATE	
WEIGHT ?? LBS		R&D		SCALE: NONE DO NOT SCALE DRAWING	
APPR.		SIZE C		DWG. NO. 1015611	
FINISH		S/C CRANK PULLEY / S/C BELT ROUTING		REV. B	
MATERIAL		1998-2001 FORD 6.8L V10		SHEET 1 OF 1	
FINISH		300 BEACON PLACE OXNARD, CA 93033		REV. B	
MATERIAL		TEL: (805) 604-1336 FAX: (805) 604-1337		SHEET 1 OF 1	



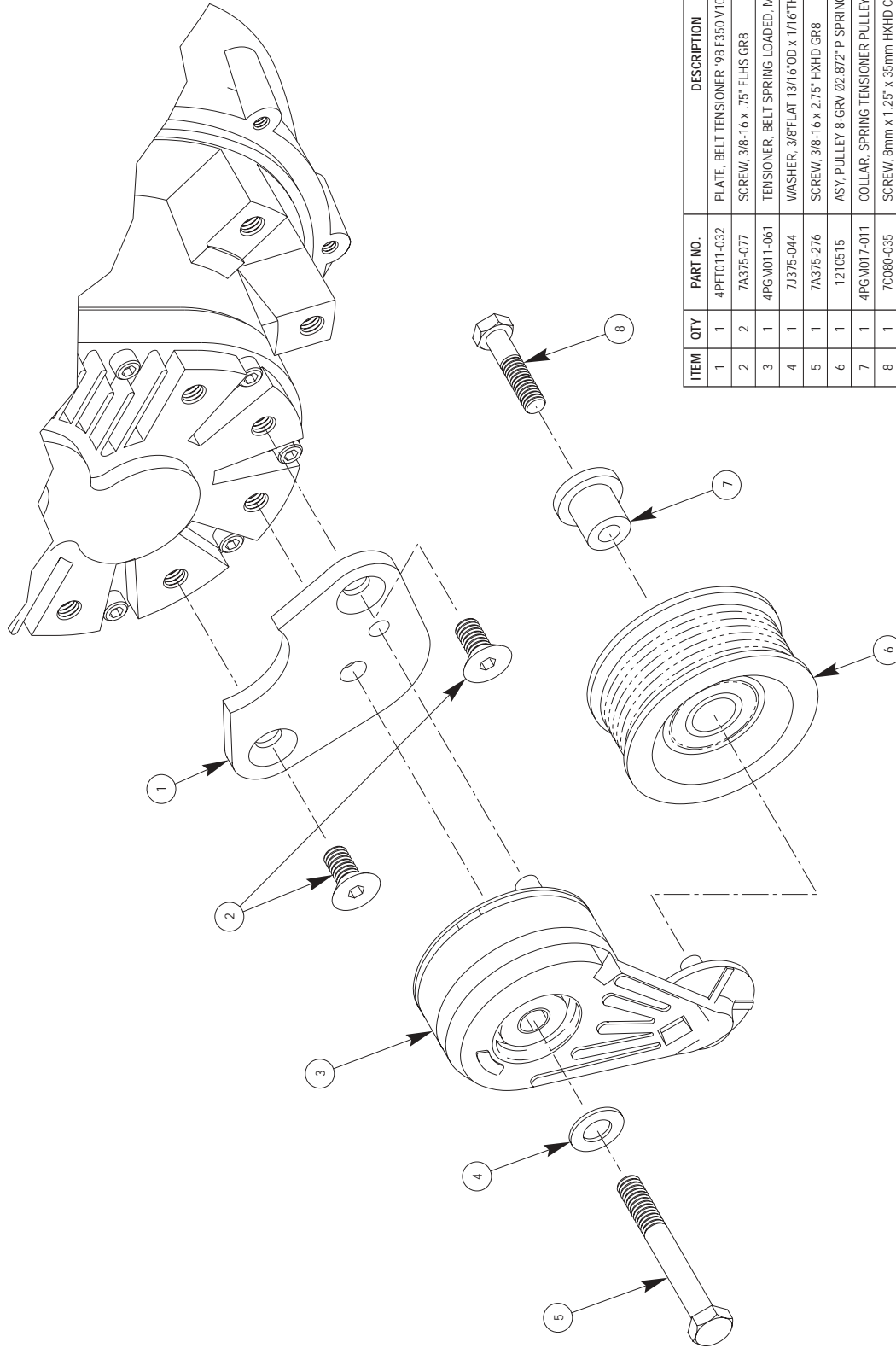

ITEM	QTY	PART NO.	DESCRIPTION
1	1	4PFT011-032	PLATE, BELT TENSIONER '98 F350 V10
2	2	7A375-077	SCREW, 3/8-16 x .75' FLHS GR8
3	1	4PGM011-061	TENSIONER, BELT SPRING LOADED, MODIFIED
4	1	7J375-044	WASHER, 3/8"FLAT 13/16"OD x 1/16"THK
5	1	7A375-276	SCREW, 3/8-16 x 2.75' HXHD GR8
6	1	1210515	ASY, PULLEY 8-GRV Ø2.872" P SPRING TENSIONER
7	1	4PGM017-011	COLLAR, SPRING TENSIONER PULLEY
8	1	7C080-035	SCREW, 8mm x 1.25' x 35mm HXHD CLASS 8.8

UNLESS OTHERWISE SPECIFIED
DIMENSIONS ARE IN INCHES
TOLERANCES ARE: XX+.01
DECIMALS: .XX±.005
FRACTIONS: ±1/2
ANGLES: ±1/16

CAD GENERATED DRAWING,
DO NOT MANUALLY UPDATE

APPROVALS	DATE
JFC	10/21/98
ENGINEERING	
R&D	
APPR.	
WEIGHT	

SEE PARTS LIST
FINISH NONE
MATERIAL NONE
SCALE: NONE DO NOT SCALE DRAWING

PAXTON
SPECIALTY PARTS

1300 BEACON PLACE OXNARD, CA 93033
TEL: (805) 604-1336 FAX: (805) 604-1337

1998-2001 FORD 6.8L V10

ASY, BELT TENSIONER

SIZE E DWG. NO. 1016911 REV. E

SCALE: NONE DO NOT SCALE DRAWING SHEET 1 OF 1

Appendix E 1016911 ASY, BELT TENSIONER

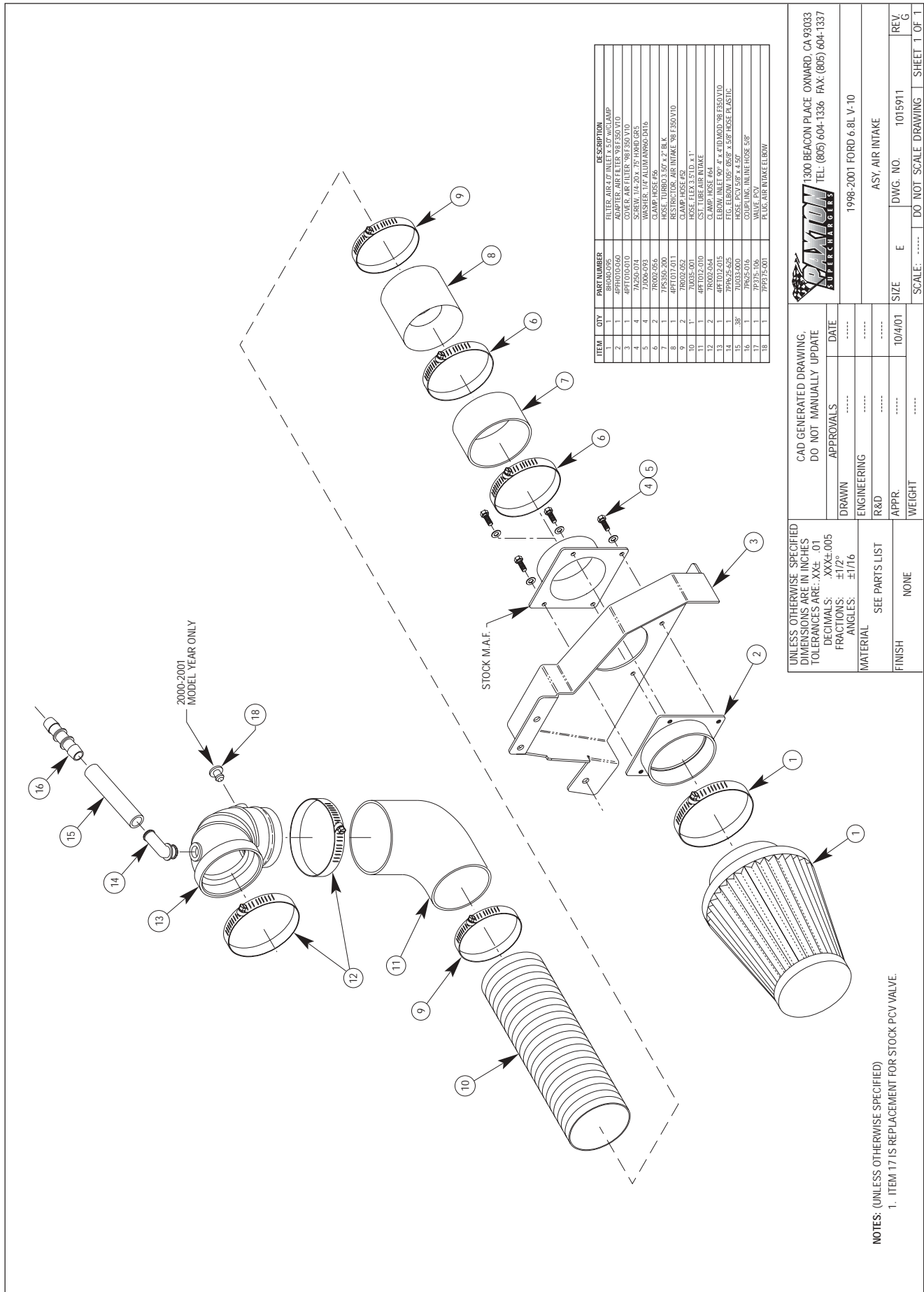

ITEM	QTY	PART NUMBER	DESCRIPTION
1	1	8B000095	FILTER AIR 4.17 INLET X 5.07 W/CLAMP
2	1	48T02010	CLAMP HOSE 4.17 INLET X 5.07 W/CLAMP
3	1	48T02010	CLAMP HOSE 4.17 INLET X 5.07 W/CLAMP
4	4	7A250-074	SCREW 1/4-20 X 3/5 HARD GR5
5	4	7A006-093	WASHER 1/4 ALUM AN660 DN16
6	2	7R002-056	CLAMP HOSE #56
7	1	7P550-200	HOSE TUBBO 3.50 X 2.75 BLK
8	1	7R002-062	CLAMP HOSE #62
9	2	7R002-062	CLAMP HOSE #62
10	1	7A035-001	HOSE FLEX 3.51 I.D. X 1"
11	1	48T02-010	CST. TUBE AIR INTAKE
12	2	7R002-064	CLAMP HOSE #64
13	1	48T02-015	ELEPH INLET 1.89 X 2.41D MOD-98 F550V10
14	1	48T02-015	ELEPH INLET 1.89 X 2.41D MOD-98 F550V10
15	38	7A033-000	HOSE PCV 1/8" X 4.50"
16	1	7A025-016	COUPLING INLINE HOSE 5/8"
17	1	7P375-106	VALVE PCV
18	1	7P975-001	PLUG AIR INTAKE ELBOW

PAXTON
 SPECIALTY AIR INTAKE & FILTERS

1300 BEACON PLACE OXNARD, CA 93033
 TEL: (805) 604-1336 FAX: (805) 604-1337

1998-2001 FORD 6.8L V-10

ASY, AIR INTAKE

SCALE: E DO NOT SCALE DRAWING SHEET 1 OF 1

DATE: 10/4/01

UNLESS OTHERWISE SPECIFIED
 DIMENSIONS ARE IN INCHES
 TOLERANCES ARE: XX±.01
 DECIMALS: .XX±.005
 FRACTIONS: ±1/2"
 ANGLES: ±1/16

SEE PARTS LIST

FINISH: NONE

WEIGHT: NONE

APPROVALS: DRAWN: R&D: APPR: WEIGHT: DATE: 10/4/01

CAD GENERATED DRAWING,
 DO NOT MANUALLY UPDATE

1998-2001 FORD 6.8L V-10

ASY, AIR INTAKE

DWG. NO. 1015911

REV. G

NOTES: (UNLESS OTHERWISE SPECIFIED)
 1. ITEM 17 IS REPLACEMENT FOR STOCK PCV VALVE.

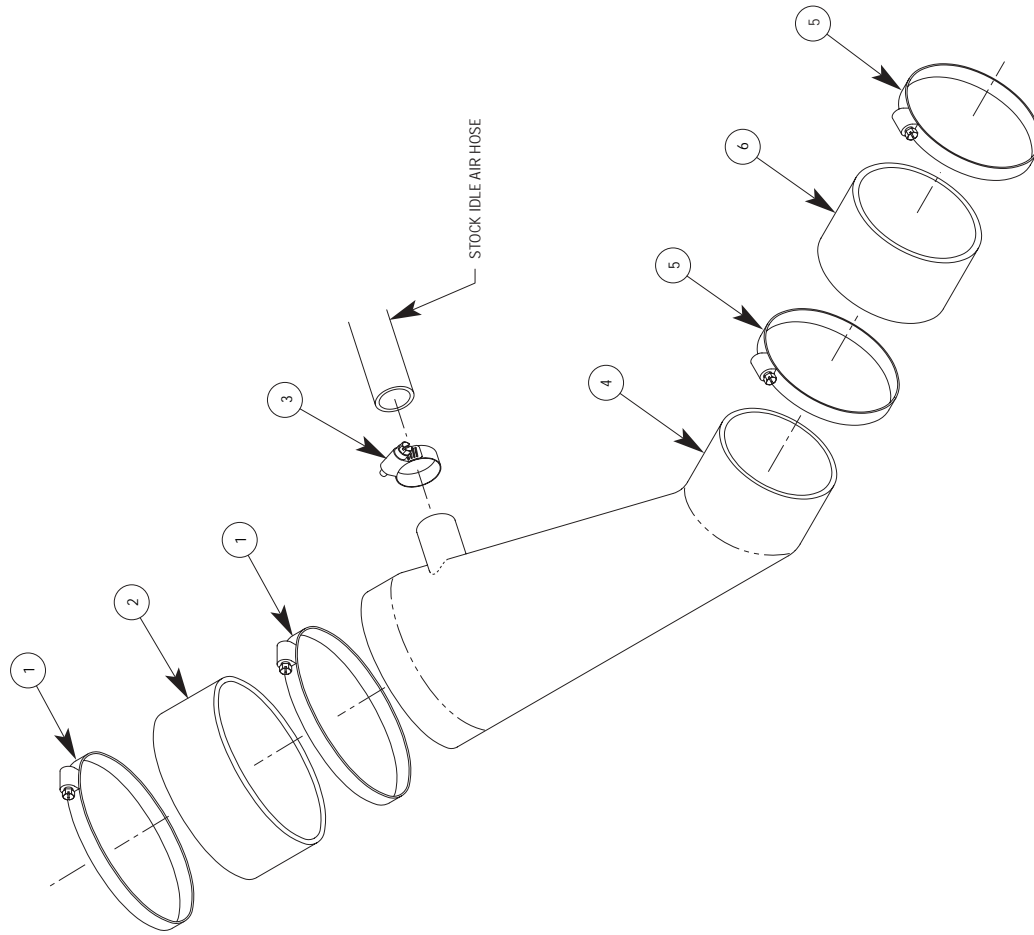

ITEM	QTY	PART NO.	DESCRIPTION
1	2	7R002-072	CLAMP HOSE #72
2	1	7PS425-200	HOSE, 4.25" I.D. x 2' LG BLK
3	1	7R002-012	CLAMP HOSE #12
4	1	4PFT012-020	CST. TUBE DISCHARGE '98 F350 V10
5	2	7R002-048	CLAMP HOSE #48
6	1	7PS300-200	HOSE, TURBO 3.00" I.D. x 2' LG BLK

UNLESS OTHERWISE SPECIFIED
 DIMENSIONS ARE IN INCHES
 TOLERANCES ARE: .XXX ± .01
 DECIMALS: .XXX ± .005
 FRACTIONS: ± 1/2
 ANGLES: ± 1/16

CAD GENERATED DRAWING.
 DO NOT MANUALLY UPDATE

DATE	10/28/98
APPROVALS	RV
DRAWN	RV
ENGINEERING	----
R&D	----
APPR.	----
WEIGHT	----- LBS

SEE PARTS LIST
 FINISH NONE

1998-2001 FORD 6.8L V10
 ASY, AIR DISCHARGE

SIZE B DWG. NO. 1016011 REV. C
 SCALE: ?? DO NOT SCALE DRAWING SHEET 1 OF 1



300 BEACON PLACE OXNARD, CA 93033
 TEL: (805) 604-1336 FAX: (805) 604-1337

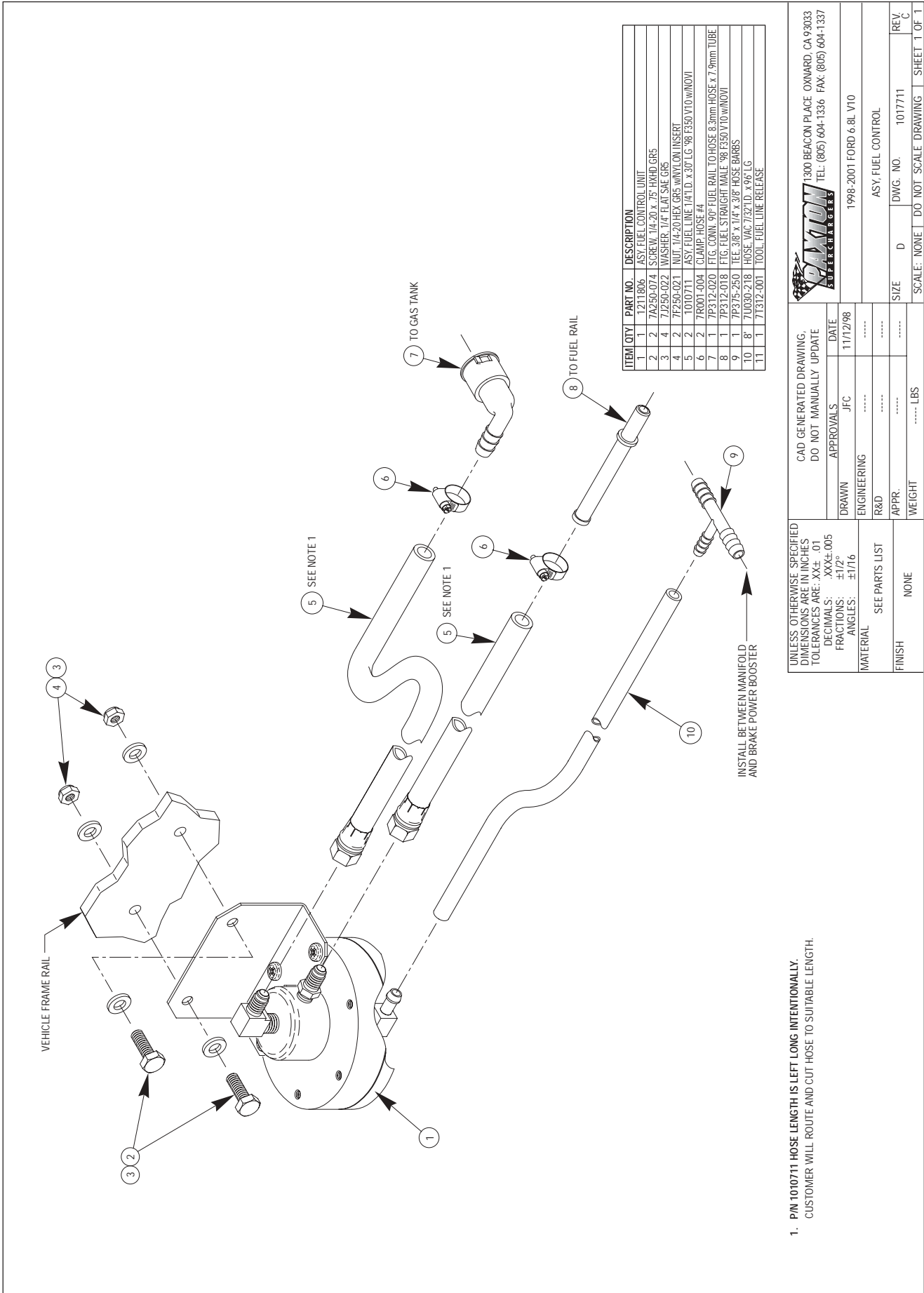

ITEM	QTY	PART NO.	DESCRIPTION
1	1	1211806	ASY FUEL CONTROL UNIT
2	2	7A250-074	SCREW 1/4-20 x .75 HEX HD GR5
3	4	7J250-022	WASHER 1/4" FLAT SAE GR5
4	2	7F250-021	NUT 1/4-20 HEX GR5 W/VALYON INSERT
5	2	1010711	ASY FUEL LINE 1/4" I.D. x .30' LG. '98 F350 V10 W/NOVI
6	2	7R001-004	CLAMP HOSE #4
7	1	7P312-020	FTG. CONN. 90° FUEL RAIL TO HOSE 8.9mm HOSE x 7.9mm TUBE
8	1	7P312-018	FTG. FUEL STRAIGHT MALE '98 F350 V10 W/NOVI
9	1	7P375-250	TEL. 3/8" x 1/4" x 3/8" HOSE BARBS
10	8	7U030-218	HOSE VAC 7/32" I.D. x .96' LG
11	1	71312-001	TOOL: FUEL LINE RELEASE

1. PIN 1010711 HOSE LENGTH IS LEFT LONG INTENTIONALLY. CUSTOMER WILL ROUTE AND CUT HOSE TO SUITABLE LENGTH.

UNLESS OTHERWISE SPECIFIED DIMENSIONS ARE IN INCHES TOLERANCES ARE: .XXX±.005 DECIMALS: .XXX±.005 FRACTIONS: ±1/2° ANGLES: ±1/16		CAD GENERATED DRAWING DO NOT MANUALLY UPDATE	
DRAWN APPROVALS JFC		DATE 11/12/98	
ENGINEERING		R&D	
SEE PARTS LIST		APPR.	
FINISH NONE		WEIGHT ----- LBS	
SCALE: NONE		DO NOT SCALE DRAWING	
SIZE D		DWG. NO. 1017711	
REV. C		SHEET 1 OF 1	

1998-2001 FORD 6.8L V10
 ASY, FUEL CONTROL



1300 BEACON PLACE ONNARD, CA 93033
 TEL: (805) 604-1336 FAX: (805) 604-1337

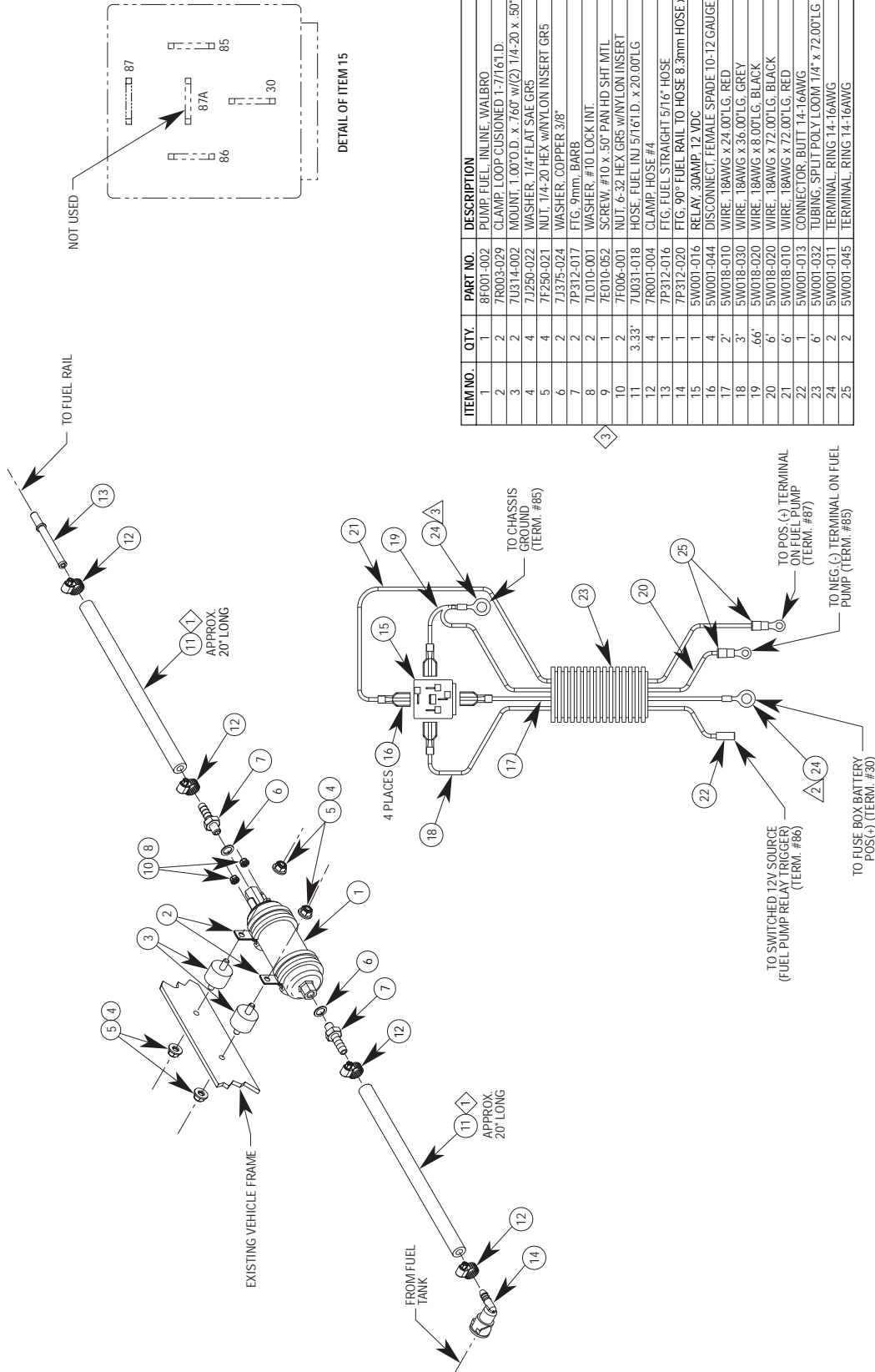

ITEM NO.	QTY.	PART NO.	DESCRIPTION
1	1	8F001-002	PUMP FUEL, IN-LINE, WALBRO
2	2	7R003-029	CLAMP LOOP CUSHIONED 1-7/16" I.D.
3	2	7U314-002	MOUNT, 1.00" O.D. x .760" W(2) 1/4-20 x .50" STUD
4	4	7J250-022	WASHER, 1/4" FLAT SAE GR5
5	4	7F250-021	NUT, 1/4-20 HEX w/NYLON INSERT GR5
6	2	7J375-024	WASHER, COPPER 3/8"
7	2	7P312-017	FIG. 9mm, BARB
8	2	7L010-001	WASHER, #10 LOCK INT.
9	2	7E010-052	SCREW, #10 x .50" PAN HD SHT. MTL.
10	2	7F006-001	NUT, 6-32 HEX GR5 w/NYLON INSERT
11	3.33'	7U031-018	HOSE, FUEL INJ 5/16" I.D. x 20.00" LG
12	4	7R001-004	CLAMP HOSE #4
13	1	7P312-016	FIG. FUEL STRAIGHT 5/16" HOSE
14	1	7P312-020	FIG. 90° FUEL RAIL TO HOSE 8.3mm HOSE x 7.9mm TUBE
15	1	5W001-016	RELAY, 30AMP, 12 VDC
16	4	5W001-044	DISCONNECT, FEMALE SPADE 10-12 GAUGE
17	2'	5W018-010	WIRE, 18AWG x 24.00" LG, RED
18	3'	5W018-030	WIRE, 18AWG x 36.00" LG, GREY
19	66'	5W018-020	WIRE, 18AWG x 8.00" LG, BLACK
20	6'	5W018-010	WIRE, 18AWG x 72.00" LG, BLACK
21	6'	5W018-010	WIRE, 18AWG x 72.00" LG, RED
22	1	5W001-013	CONNECTOR, BUTT 1/4-16AWG
23	6'	5W001-032	TUBING, SPLIT POLY LOOM 1/4" x 72.00" LG
24	2	5W001-011	TERMINAL, RING 1/4-16AWG
25	2	5W001-045	TERMINAL, RING 1/4-16AWG

UNLESS OTHERWISE SPECIFIED
DIMENSIONS ARE IN INCHES
TOLERANCES ARE: XX±.01
DECIMALS: XX±.005
FRACTIONS: ±1/2"
ANGLES: ±1/16"

SEE PARTS LIST

FINISH: NONE

WEIGHT: 2.4 LBS

CAD GENERATED DRAWING,
DO NOT MANUALLY UPDATE

APPROVALS: JFC DATE: 11/17/98

ENGINEERING: R&D

APPR. WEIGHT: 2.4 LBS

1300 BEACON PLACE OXNARD, CA 93033
TEL: (805) 604-1336 FAX: (805) 604-1337

1998-2001 FORD 6.8L V-10
ASY, AUX FUEL SYSTEM

SCALE: 1:2 DO NOT SCALE DRAWING

SIZE: D DWG. NO. 1017721 REV. K

SHEET 1 OF 1

- NOTES: UNLESS OTHERWISE SPECIFIED
- ITEM 11, HOSE LENGTH IS LEFT LONG INTENTIONALLY. CUSTOMER WILL ROUTE AND CUT HOSE TO SUITABLE LENGTH.
 - ALL FUEL FITTINGS MUST BE FULLY TIGHTENED PRIOR TO SHIPMENT.
 - THESE ITEMS SHIP LOOSE.

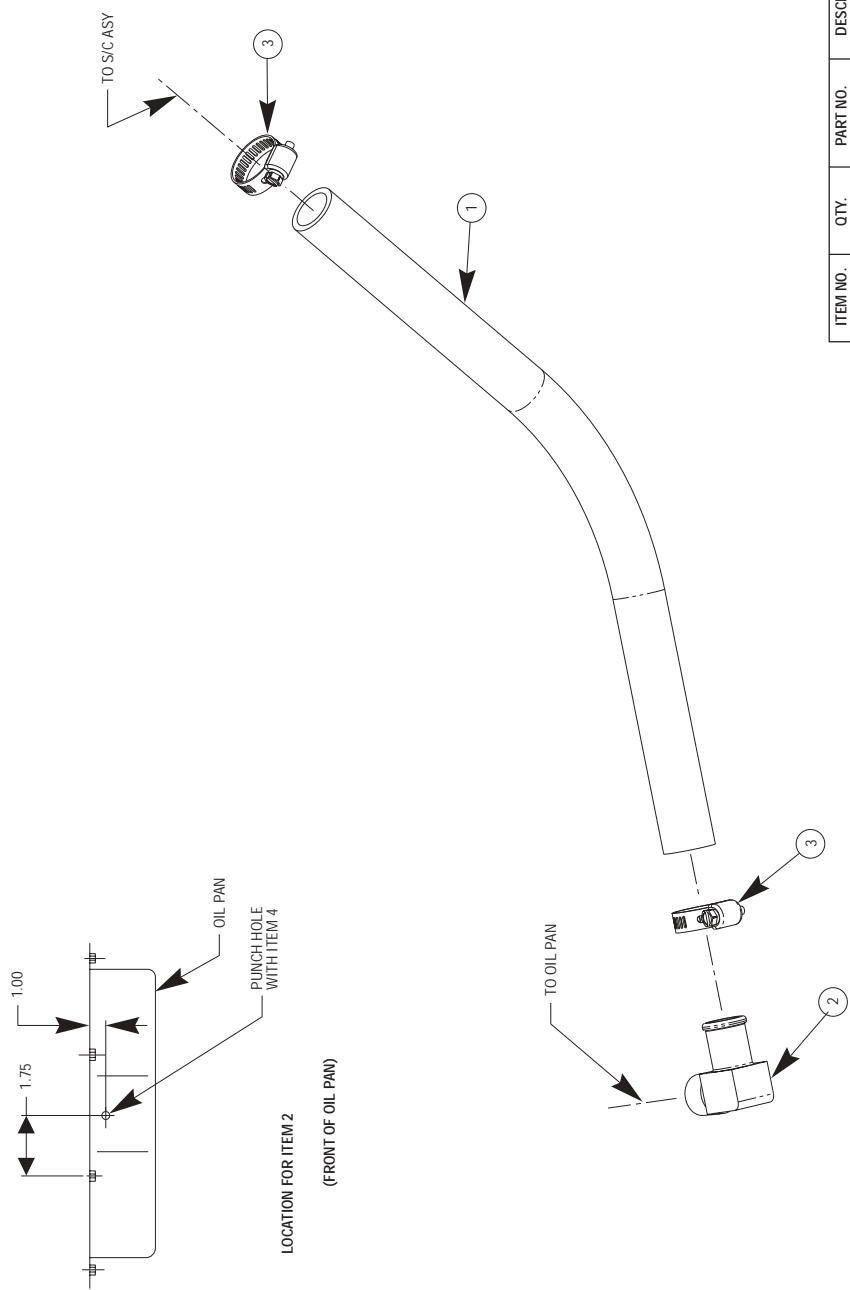

ITEM NO.	QTY.	PART NO.	DESCRIPTION
1	2.46'	7U033-000	HOSE, OIL RETURN, 5/8" x 29.5' LG.
2	1	7P375-039	FTG. HOSE END, 3/8"NPT x 5/8" BARB
3	2	7R002-010	CLAMP, HOSE, #10
4	1	7T640-011	PUNCH, OIL PAN

NOTES: UNLESS OTHERWISE SPECIFIED
 1. SHIP THIS ITEM LOOSE.

UNLESS OTHERWISE SPECIFIED
 DIMENSIONS ARE IN INCHES
 TOLERANCES ARE: .XX: .01
 DECIMALS: .XXX: .005
 FRACTIONS: ±1/2"
 ANGLES: ±1/16"

CAD GENERATED DRAWING,
 DO NOT MANUALLY UPDATE

APPROVALS	DATE
G. COMPTON	8/14/01

ENGINEERING: *****
 R&D: *****
 APPR: *****

SEE PARTS LIST
 FINISH: NONE
 WEIGHT: 0.8 LBS

1998-2001 FORD 6.8L V-10

ASSEMBLY: ASY, OIL RETURN

SIZE: C
 DWG. NO.: 1019344

SCALE: 3:4 DO NOT SCALE DRAWING

REV. INC. SHEET 1 OF 1



300 BEACON PLACE OAKLAND, CA 94612
 TEL: (805) 604-1336 FAX: (805) 604-1337

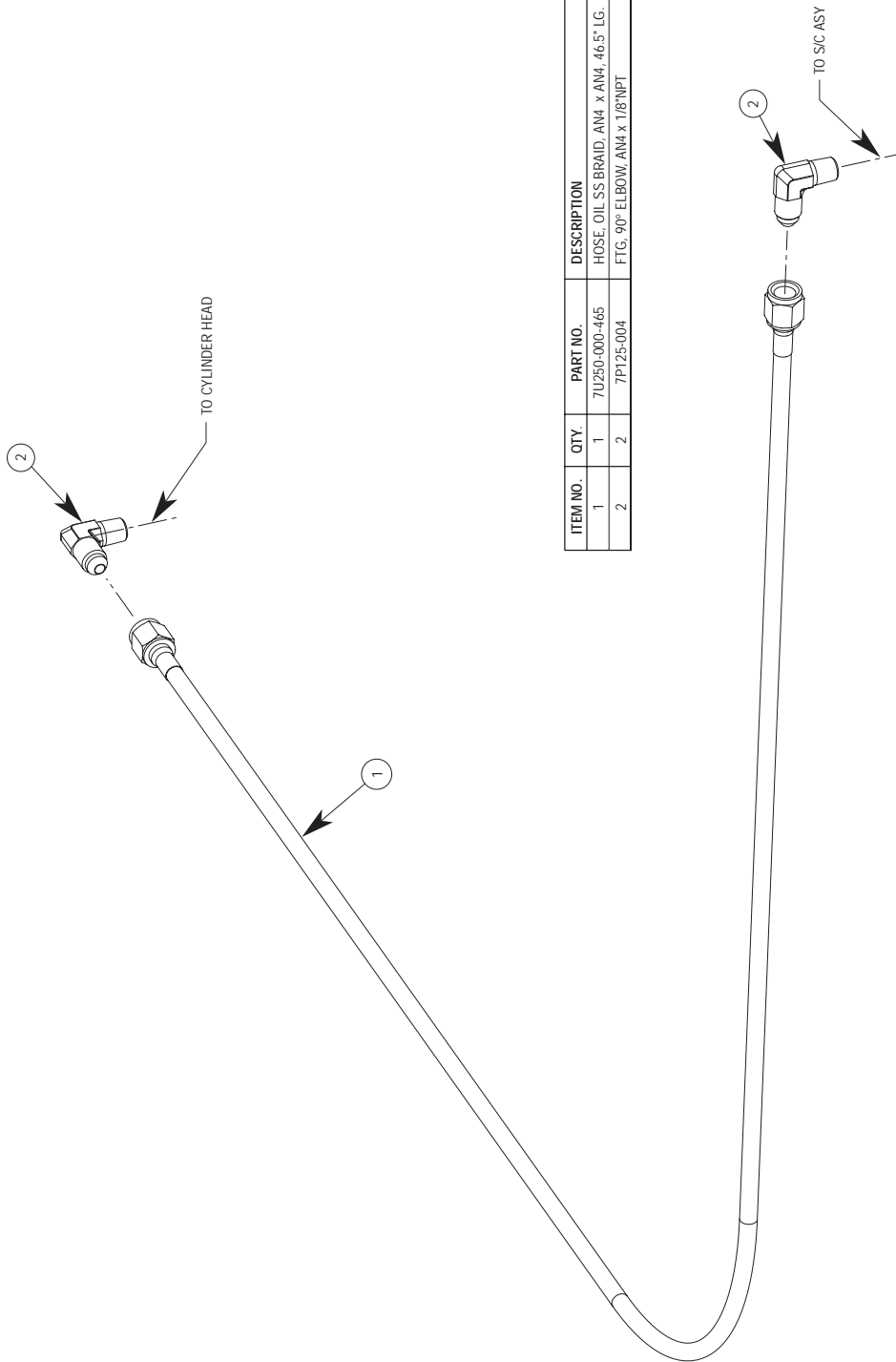

ITEM NO.	QTY	PART NO.	DESCRIPTION
1	1	7U250-000-465	HOSE, OIL SS-BRAID, AN4 x AN4, 46.5" LG.
2	2	7P125-004	FTG, 90° ELBOW, AN4 x 1/8"NPT

UNLESS OTHERWISE SPECIFIED DIMENSIONS ARE IN INCHES TOLERANCES ARE: .XX ± .01 DECIMALS: .XXX ± .005 FRACTIONS: ± 1/2" ANGLES: ± 1/16"	CAD GENERATED DRAWING, DO NOT MANUALLY UPDATE		300 BEACON PLACE OXNARD, CA 93033 TEL: (805) 604-1336 FAX: (805) 604-1337	
	APPROVALS	DATE	1998-2001 FORD 6.8L V-10	
DRAWN	G. COMPTON	11/15/01	1998-2001 FORD 6.8L V-10	
ENGINEERING	-----	-----	1998-2001 FORD 6.8L V-10	
R&D	-----	-----	1998-2001 FORD 6.8L V-10	
APPR.	-----	-----	1998-2001 FORD 6.8L V-10	
FINISH	NONE	0.2 LBS	1998-2001 FORD 6.8L V-10	
SEE PARTS LIST	-----	-----	1998-2001 FORD 6.8L V-10	
WEIGHT	0.2 LBS	-----	1998-2001 FORD 6.8L V-10	
ASSEMBLY INFORMATION			1998-2001 FORD 6.8L V-10	
SIZE	C	DWG. NO.	1019350	
SCALE:	3:4	DO NOT SCALE DRAWING	1019350	
SHEET INFORMATION			1019350	
SHEET 1 OF 1			1019350	



Appendix K 101793450 ASY, SLUPERCHARGER OIL FEED



**Paxton Automotive . 1300 Beacon Place . Oxnard CA 93033
888 9-PAXTON . FAX (805) 604-1337 • www.paxtonautomotive.com**